

8979015COM Wall Cabinet

system
build 

Date of Purchase ___ / ___ / ___
Lot Number:

B348979015COM0

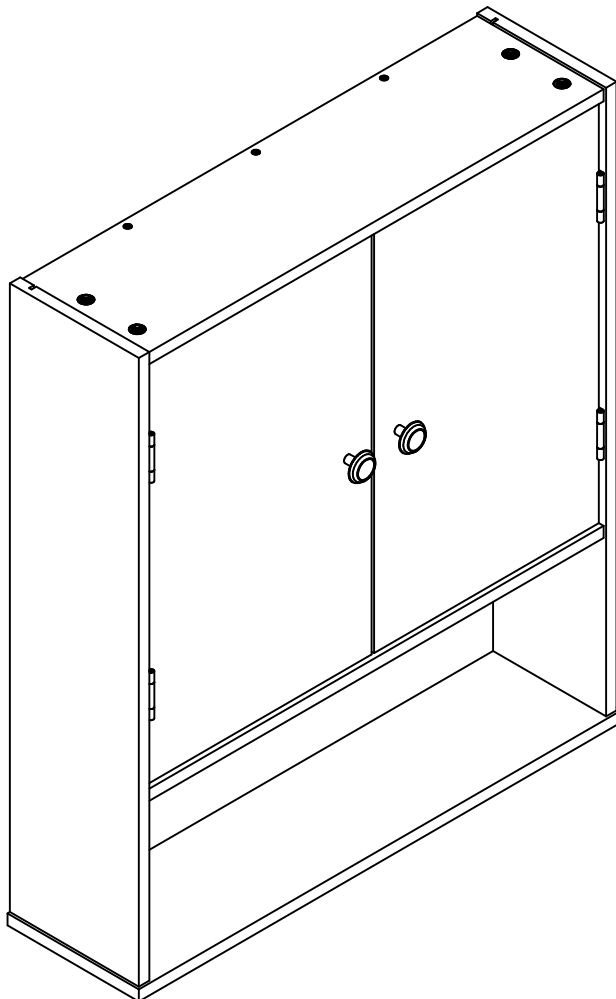

THIS INSTRUCTION BOOKLET CONTAINS **IMPORTANT** SAFETY INFORMATION. PLEASE READ AND KEEP FOR FUTURE REFERENCE.

Do Not Return This Product!

Contact our customer service team for help first.

Call: 1-866-452-4081 (toll free)

Monday-Friday 9am - 5pm CST

Visit: www.systembuild.com



WARNING

- Unit can tip over causing severe injury or death.
- Anchor unit to stud in wall (if instructed to).
- Do Not allow children to climb on unit.
- Put heavy items on lower shelves or drawers.

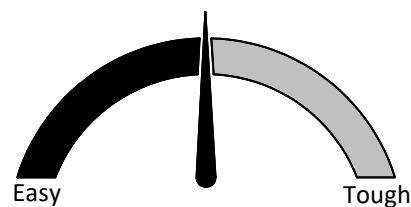

Assembly Difficulty Meter

For the latest information on SystemBuild products
follow us at Ameriwood Home



Contact Us!

Do NOT return this product!

Contact our friendly customer service team first for help.



Visit systembuild.com to view the limited warranty valid in the U.S. and Canada.

Assembly Tips



Helpful Hints

PEOPLE NEEDED FOR ASSEMBLY: **1-2**
ESTIMATED ASSEMBLY TIME: **1 HOUR**

- Open your item in the area you plan to keep it to avoid excessive heavy lifting.
- Identify, sort and count the parts before attempting assembly.
- Compression dowels are lightly tapped in with a hammer.
- Slides are labeled with a **R** (right) and **L** (left) for proper placement.
- Make sure to always face the point on the top of the Cam Lock towards the outer edge.
- Use all the nails provided for the back panel and spread them out equally.
- Back panel must be used to make sure your unit is sturdy.
- Do NOT use harsh chemicals or abrasive cleaners on this item.
- Never push, pull, or drag your furniture.

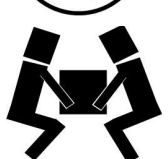

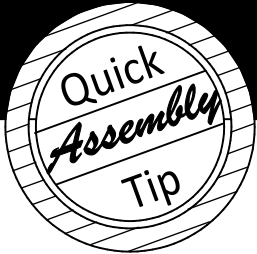

Before You Start

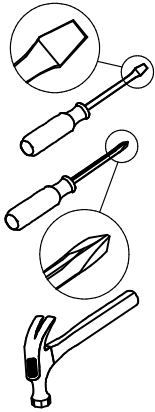

- ✓ Read through each step carefully and follow the proper order
- ✓ Separate and count all your parts and hardware
- ✓ Give yourself enough room for the assembly process
- ✓ Have the following tools: Flat Head Screwdriver, #2 Phillips Head Screwdriver and Hammer
- ✓ Caution: If using a power drill or power screwdriver for screwing, please be aware to slow down and stop when screw is tight. Failure to do so may result in stripping the screw.

Cam Lock Fastening System

This Cam Lock Fastening System will be used throughout the assembly process.

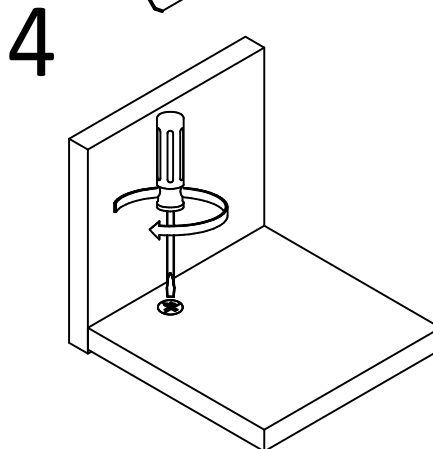
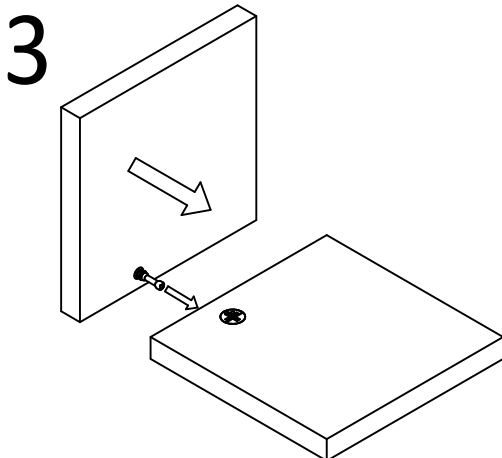
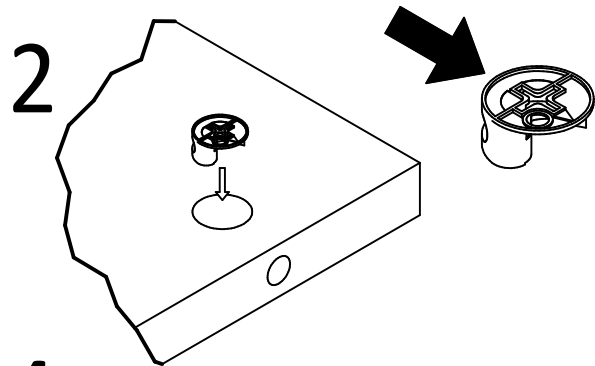
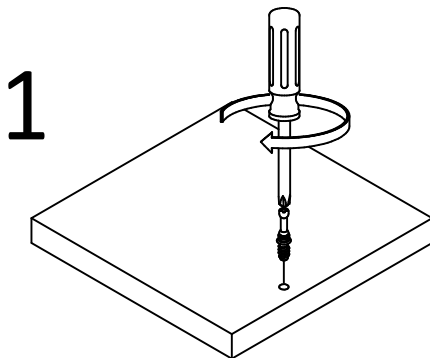

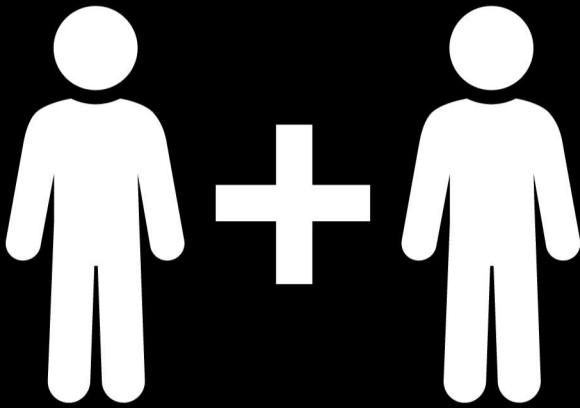

2 PEOPLE NEEDED FOR ASSEMBLY

**2 PERSONAS NECESITADAS
PARA LA ASAMBLEA**

**2 PERSONNES NÉCESSAIRES
POUR L'ASSEMBLAGE**

CAUTION: Failure to use 2 people for assembly could result in unit damage or personal injury.

PRECAUCIÓN: Si no se utilizan 2 personas para el ensamblaje, se pueden producir daños en la unidad o lesiones personales.

ATTENTION: Échec d'utiliser 2 personnes pour l'assemblage peut causer du dommage au meuble ou causer des blessures.

Board Identification

Not actual size

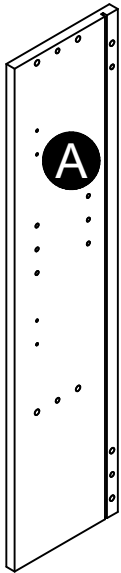

Left Panel
38979015010

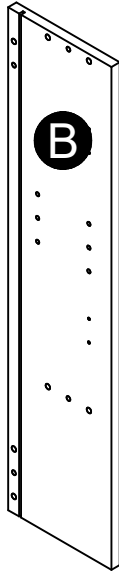

Right Panel
38979015020

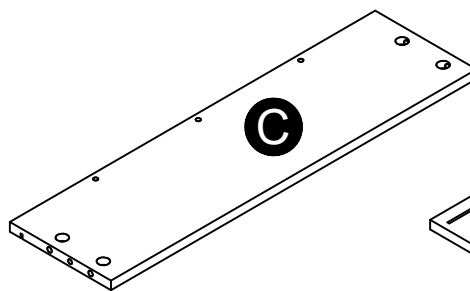

Top
38979015030

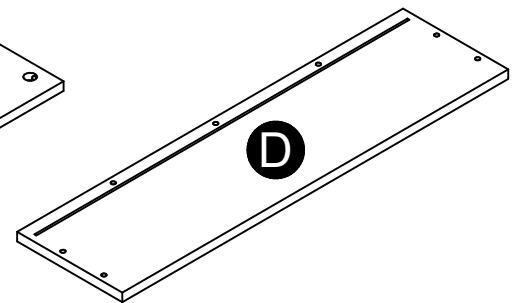

Bottom
38979015040

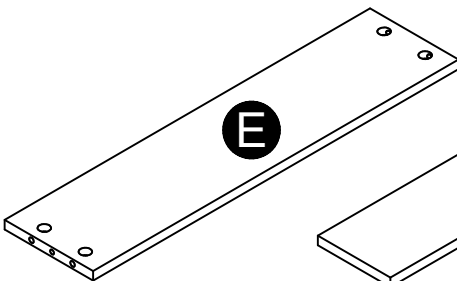

Shelf
38979015050

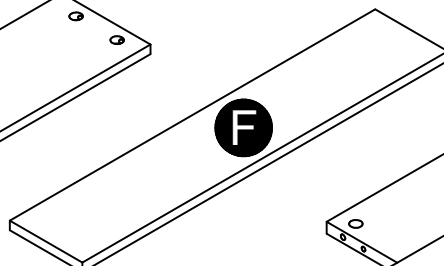

Adjustable Shelf
38979015060

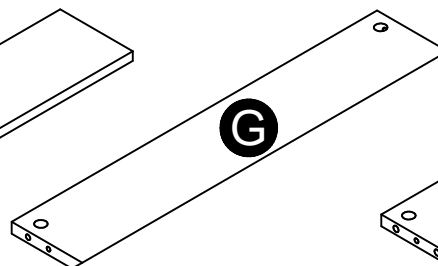

Top Rail
38979000070

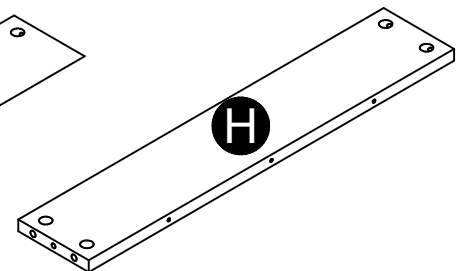

Lower Rail
38979000080

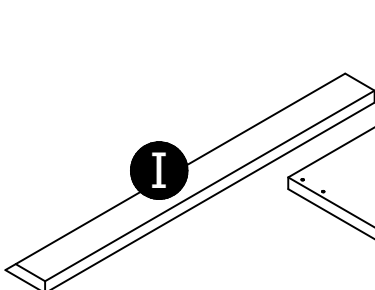

Wall Hanger
38979000090

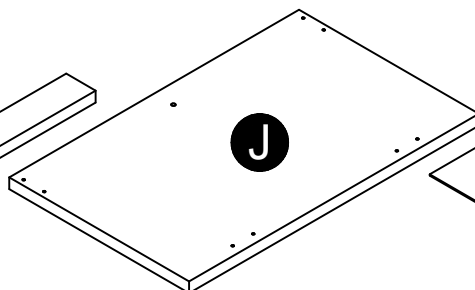

(x2)
Door
32936015100

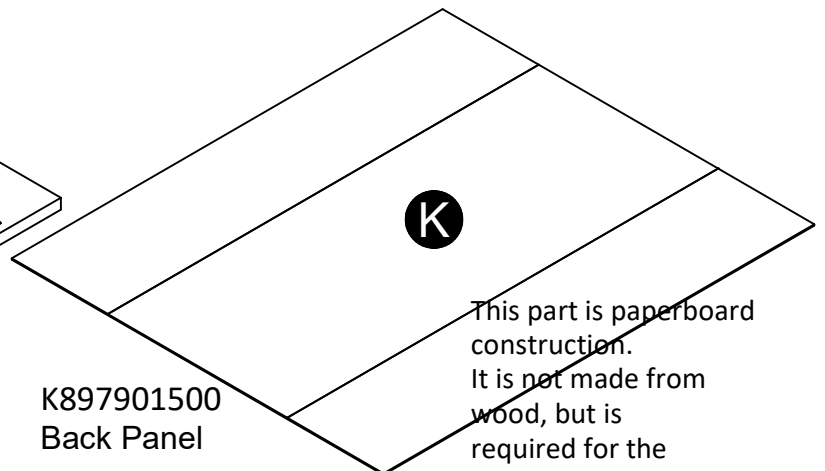

K897901500
Back Panel

This part is paperboard construction. It is not made from wood, but is required for the assembly of your unit.

Board Identification

Not actual size

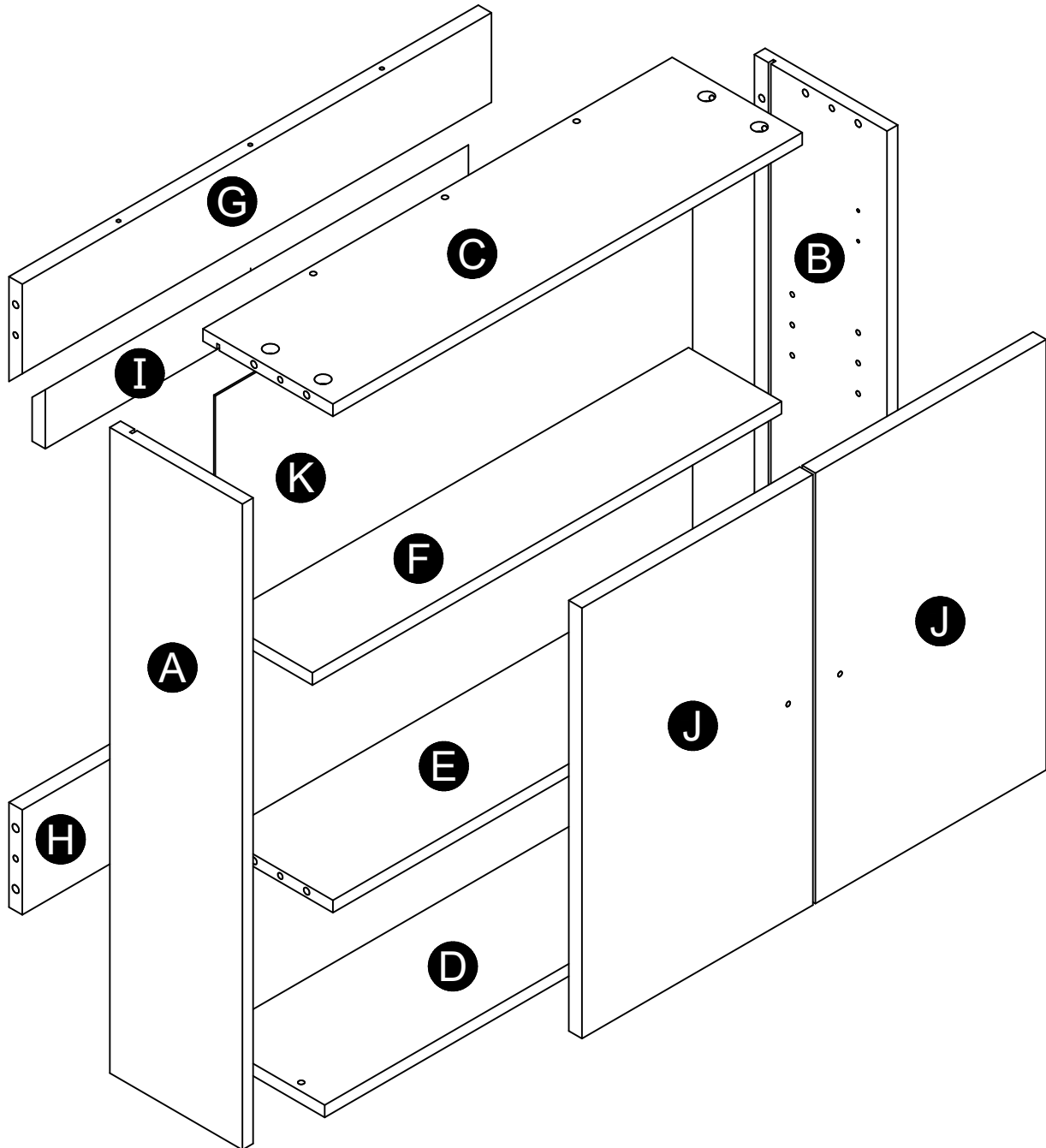

Part List

Actual Size

1

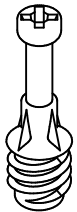

(x14)
#A22610
cam bolt

2



(x14)
#A22620
cam lock

3

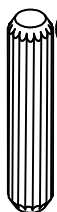

(x8)
#A21670
wood dowel

4



(x10)
#A23030
confirmat screw

5

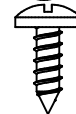

(x24)
#A12120
7/16" round head screw

6

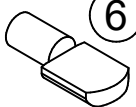

(x4)
#A80250
shelf support

7

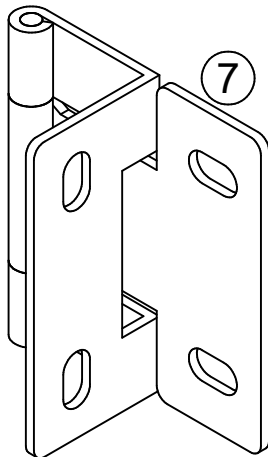

(x4)
#A60015
hinge

8

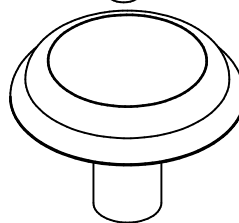

(x2)
#A51960
knob

9

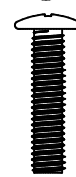

(x2)
#A17300
3/4" bolt

10a

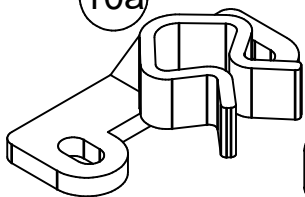

(x2)
#A30030
plastic catch kit

10b

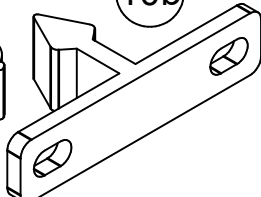

11

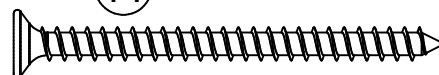

(x2)
#A13800
2-1/4" flat head screw

STEP 1

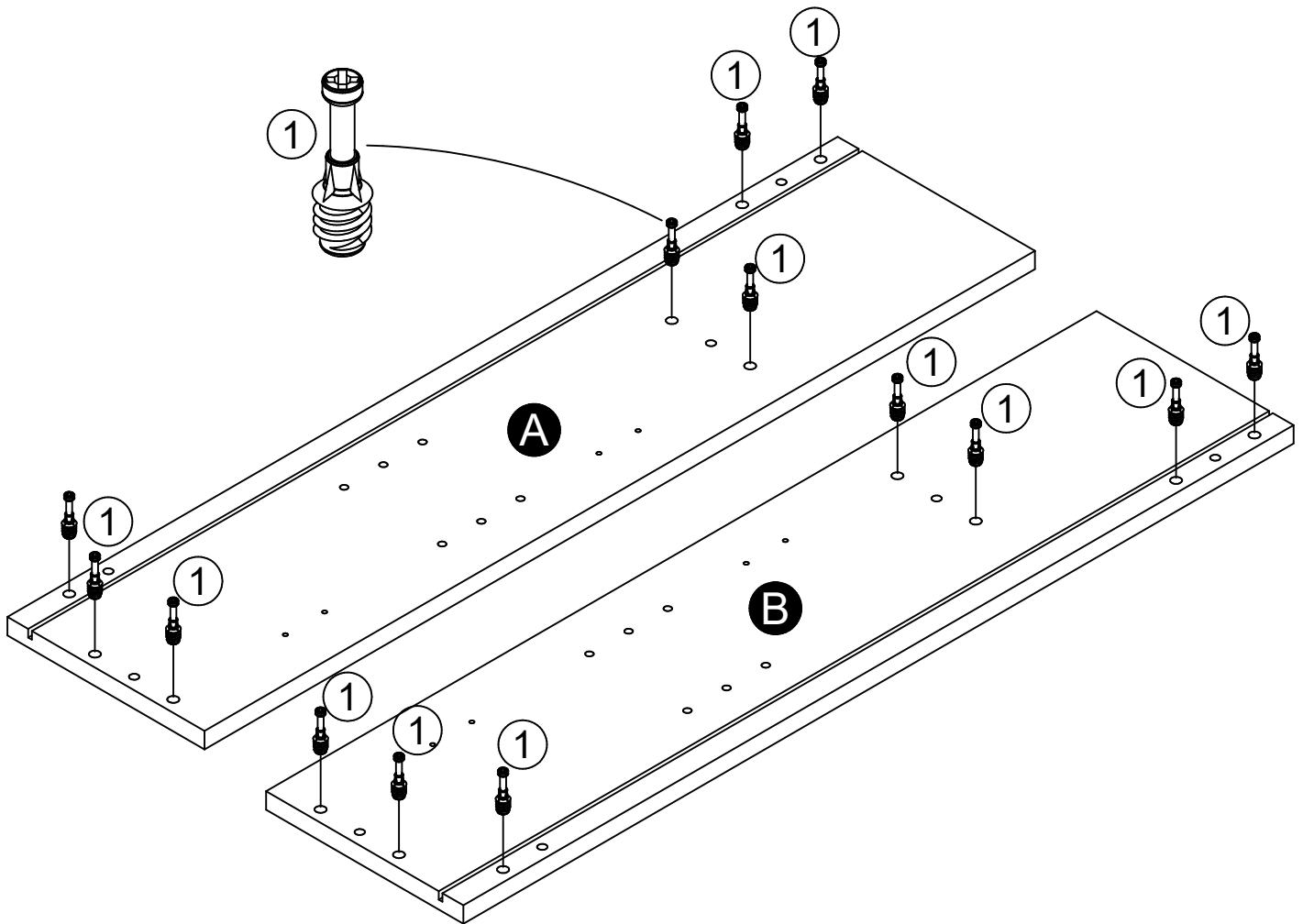
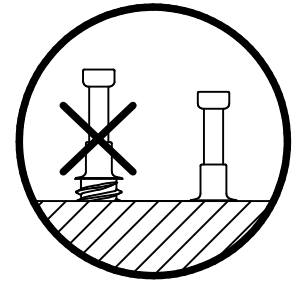
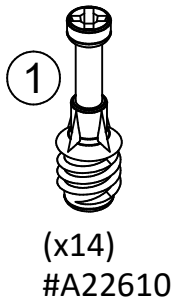
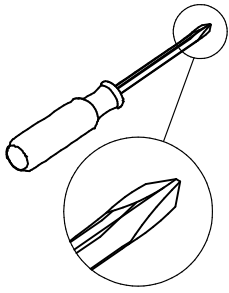

STEP 2

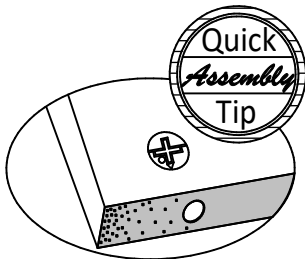
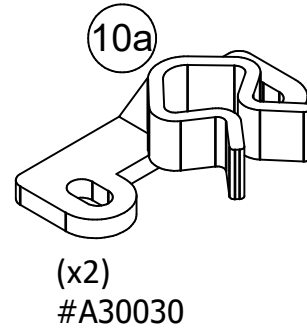
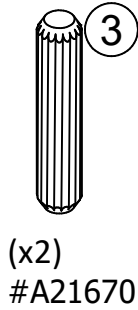
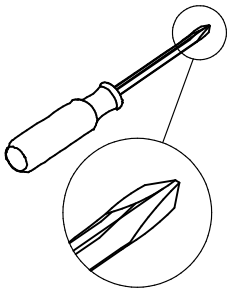

Proper orientation of CAM LOCK

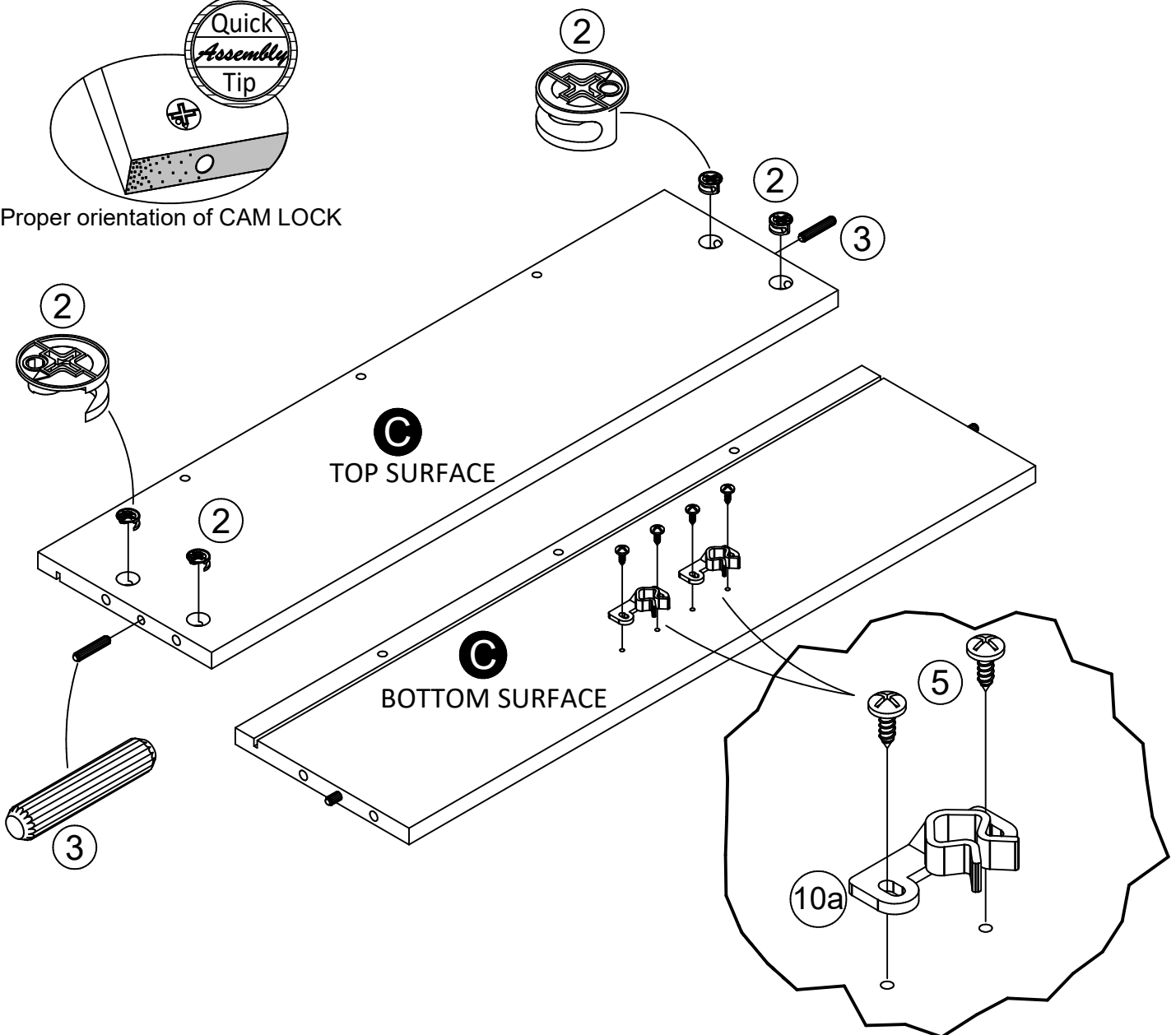

STEP 3



(x4)
#A22620

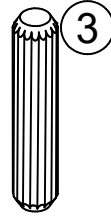

(x2)
#A21670

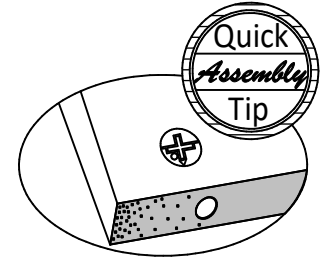

Proper orientation of CAM LOCK

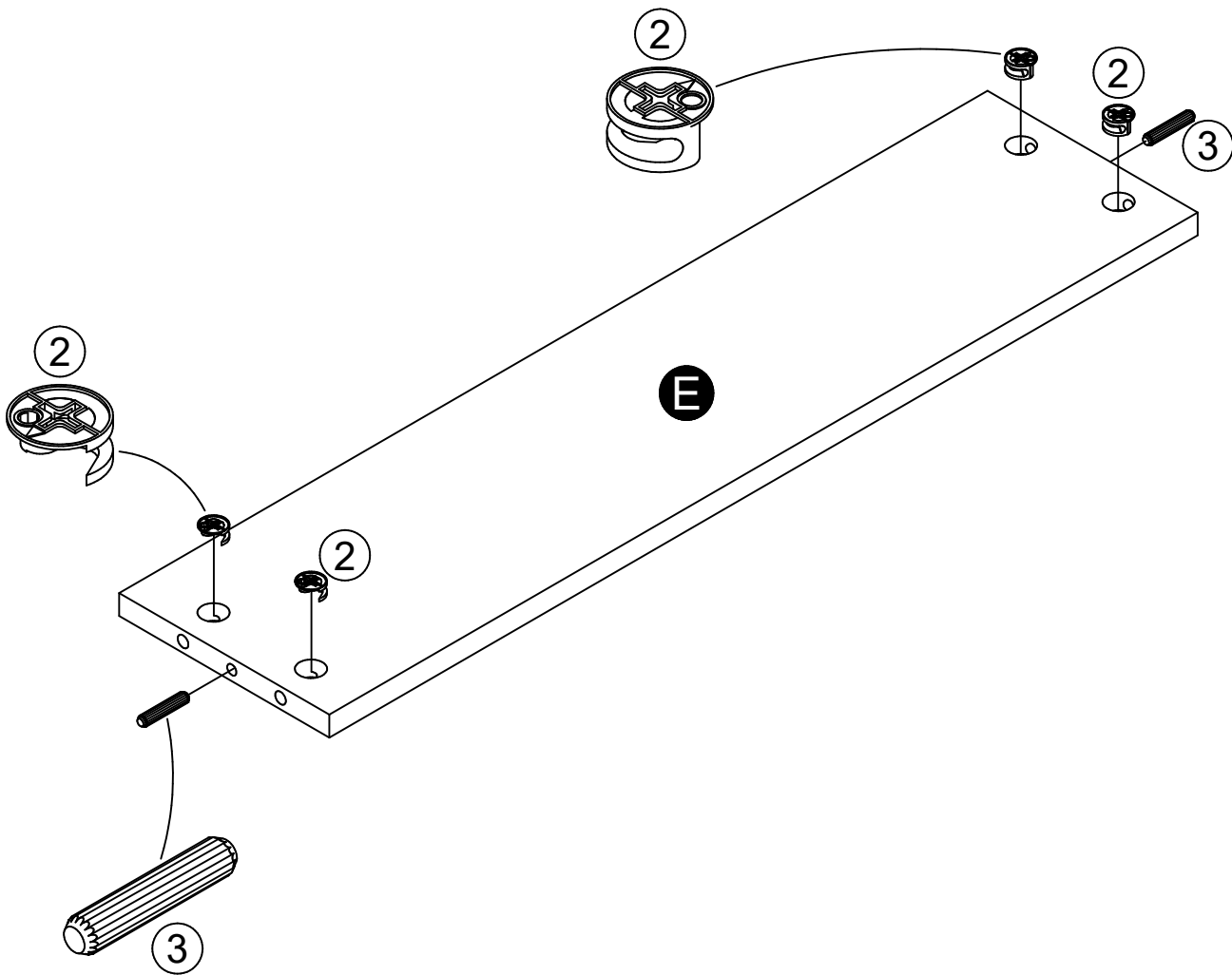

STEP 4

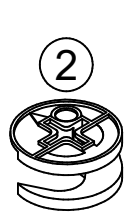

(x6)
#A22620

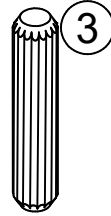

(x4)
#A21670

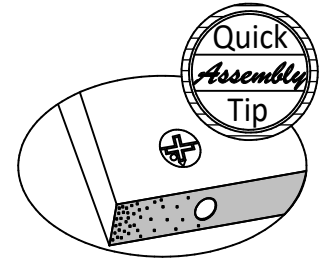

Proper orientation of CAM LOCK

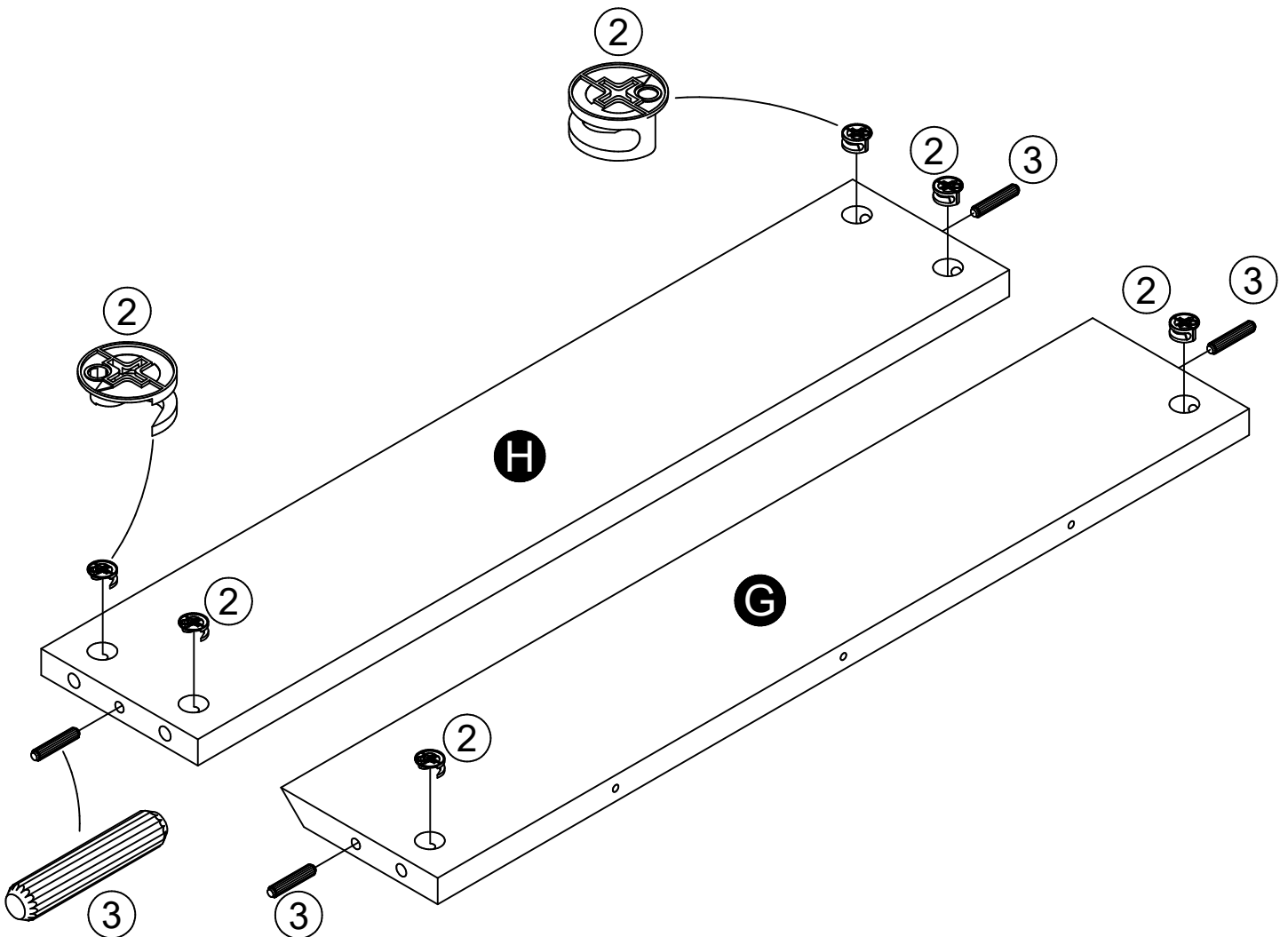

STEP 5

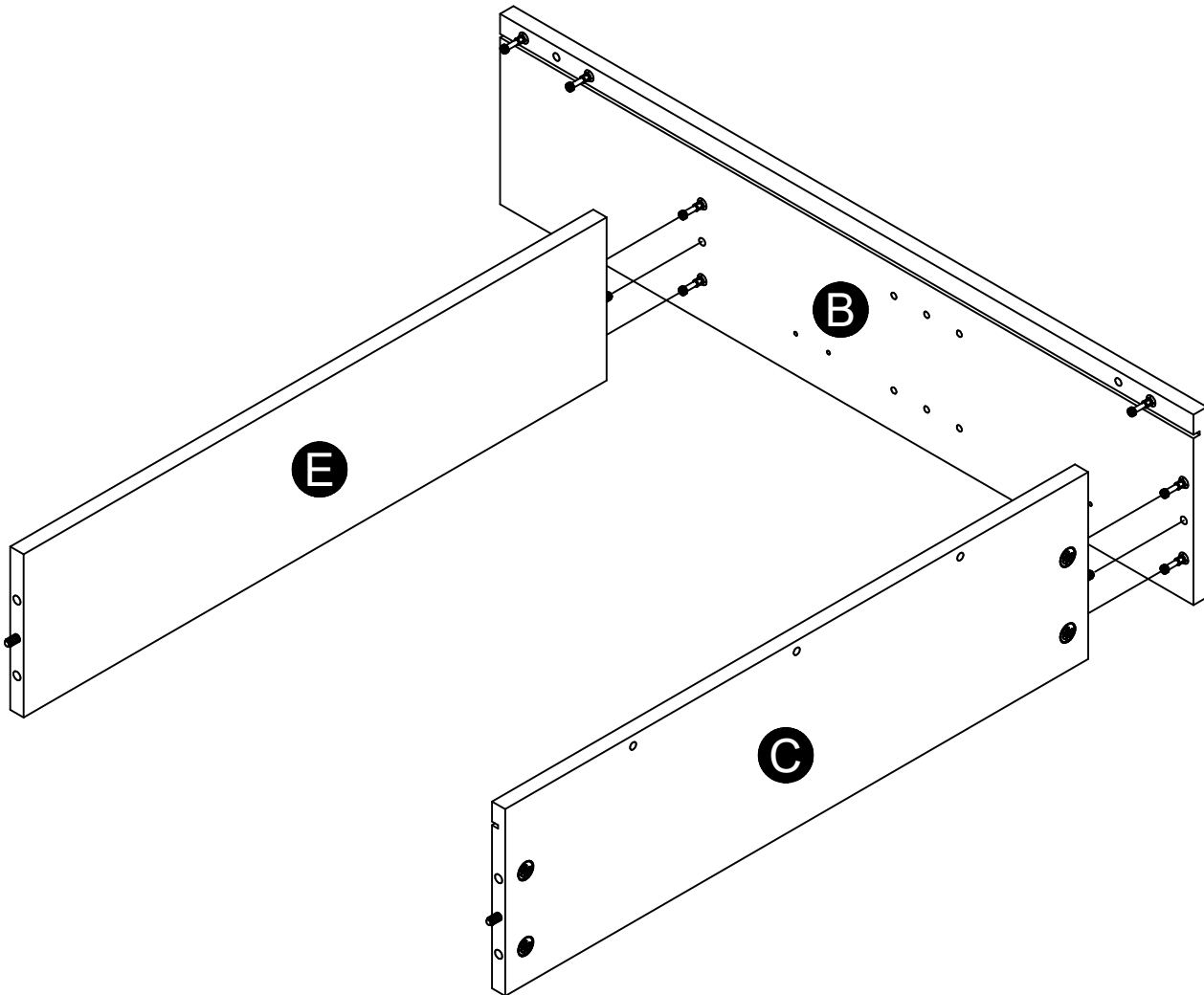
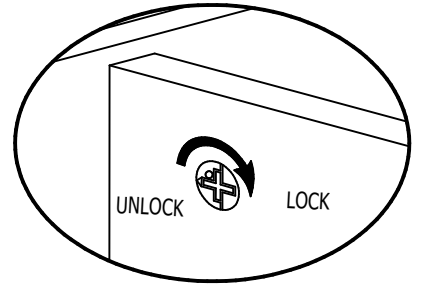
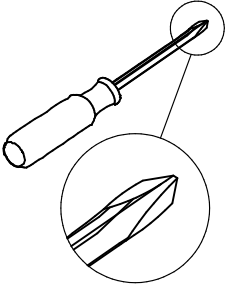

Finished edges will face down.

STEP 6

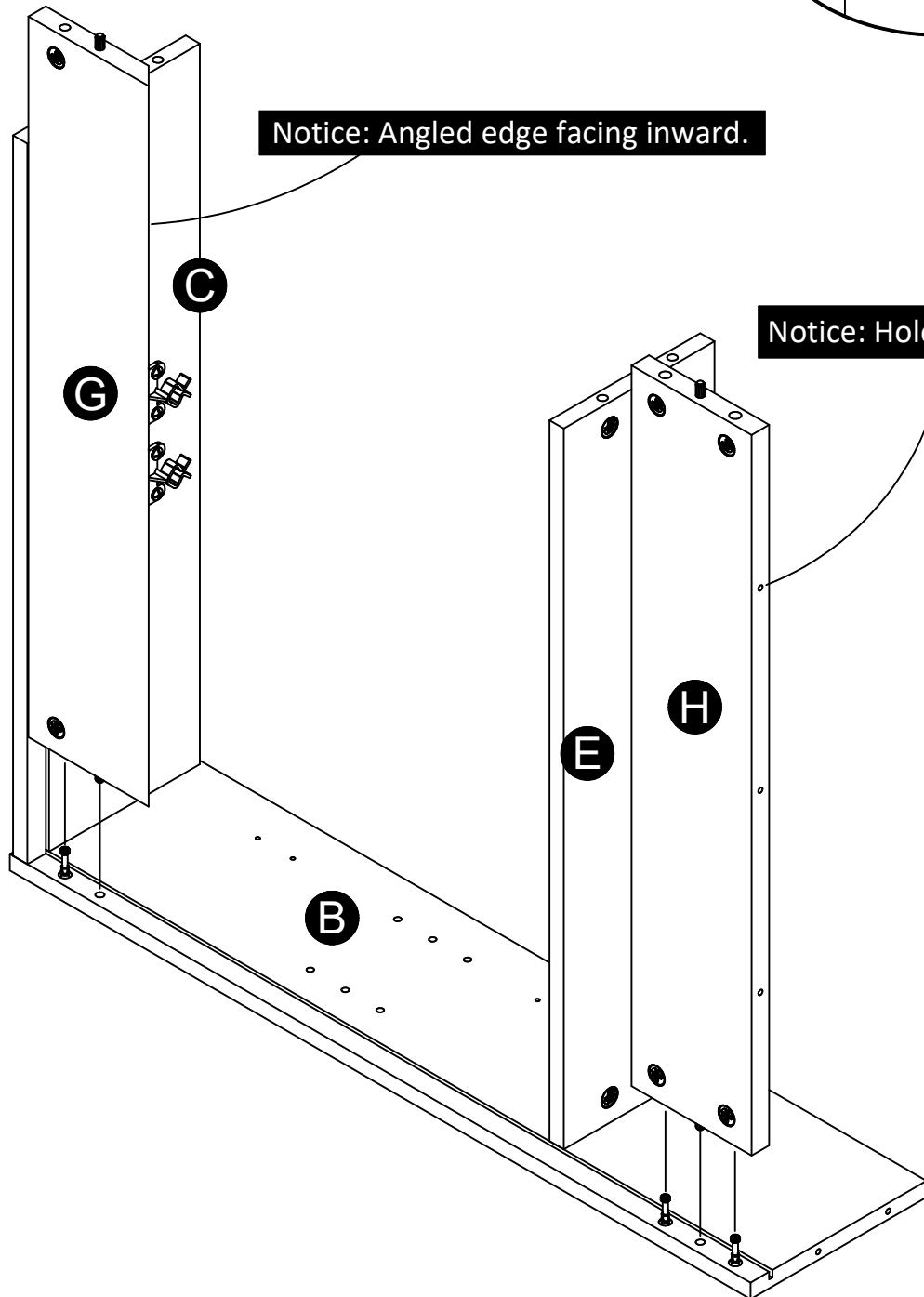
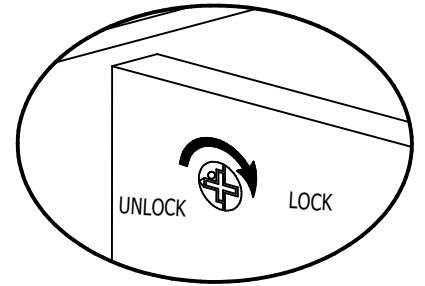
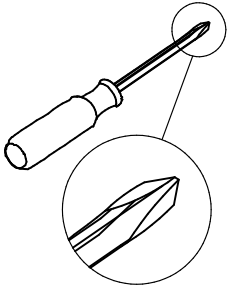

STEP 7

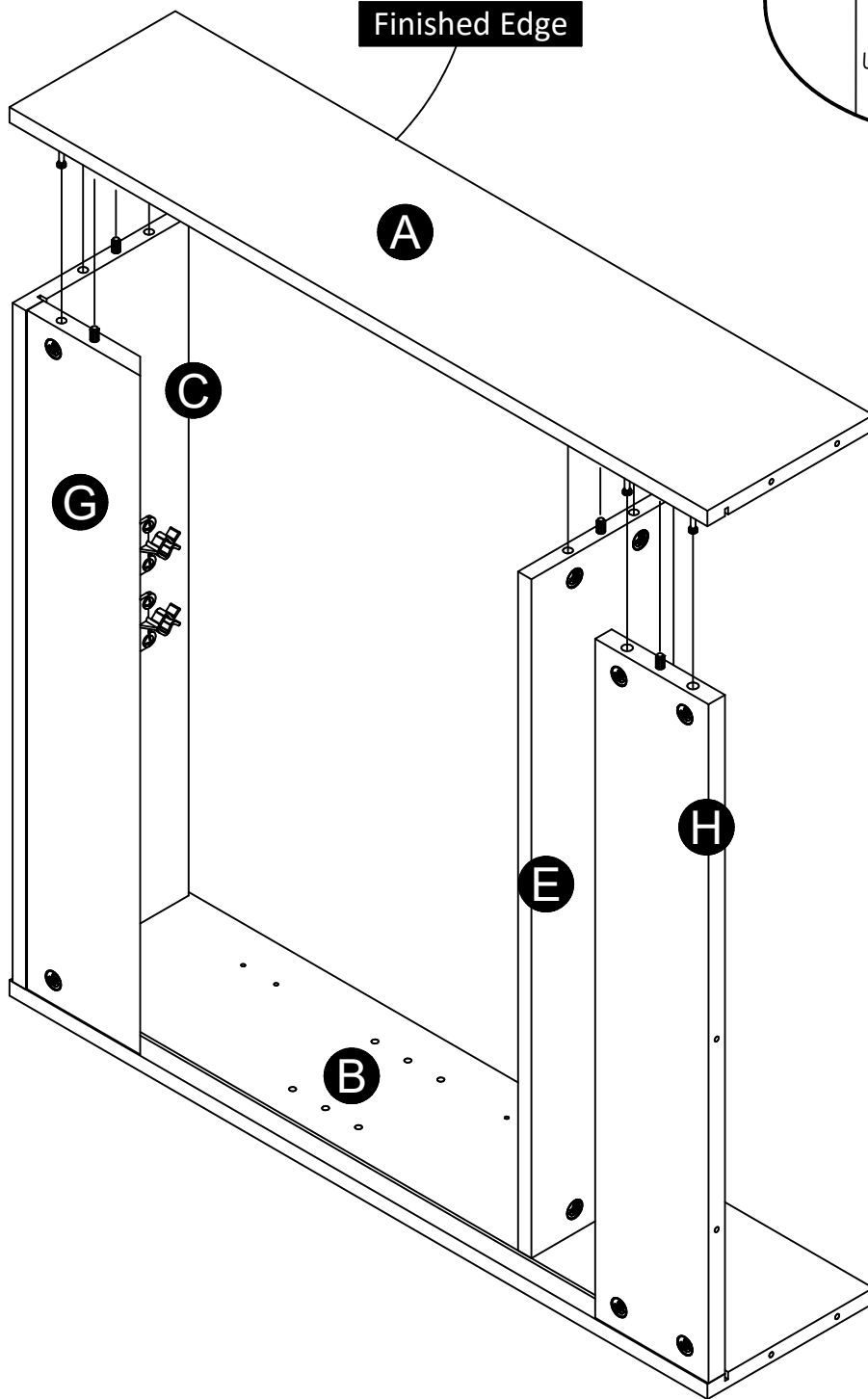
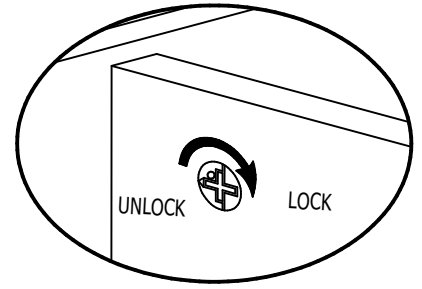
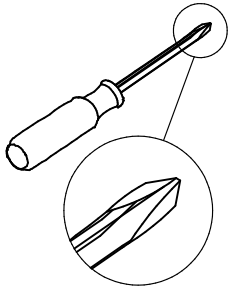

STEP 8

Unfold the back panel. Slide into groove of the left panel (A), right panel (B) and top (C).

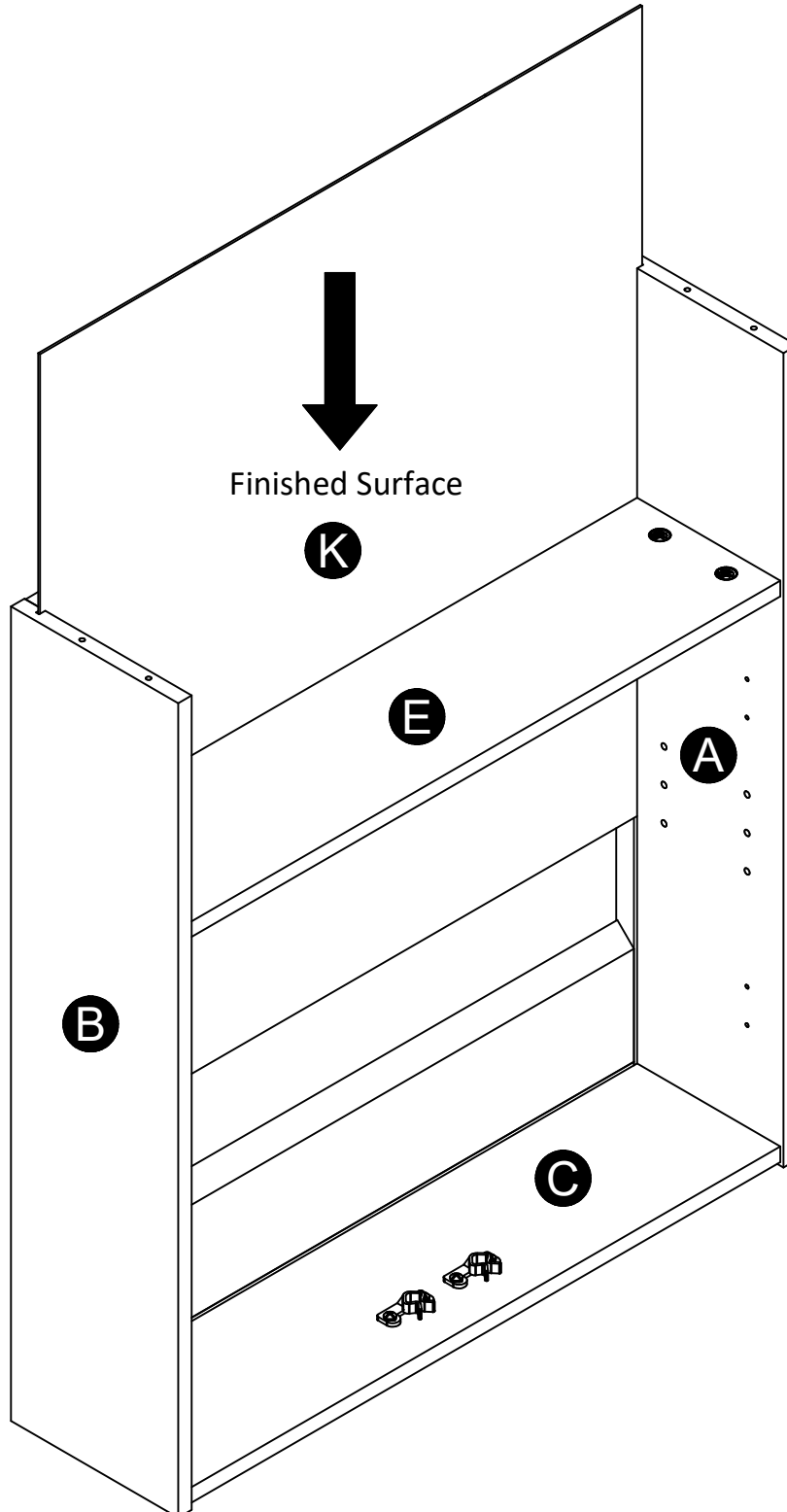

STEP 10

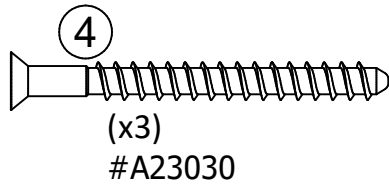
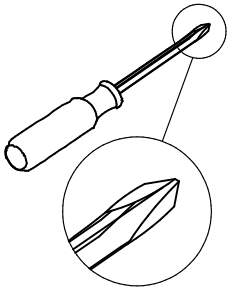

Carefully turn your unit over as shown. Fasten the top (C) to the top rail (F) as shown with screws (4).

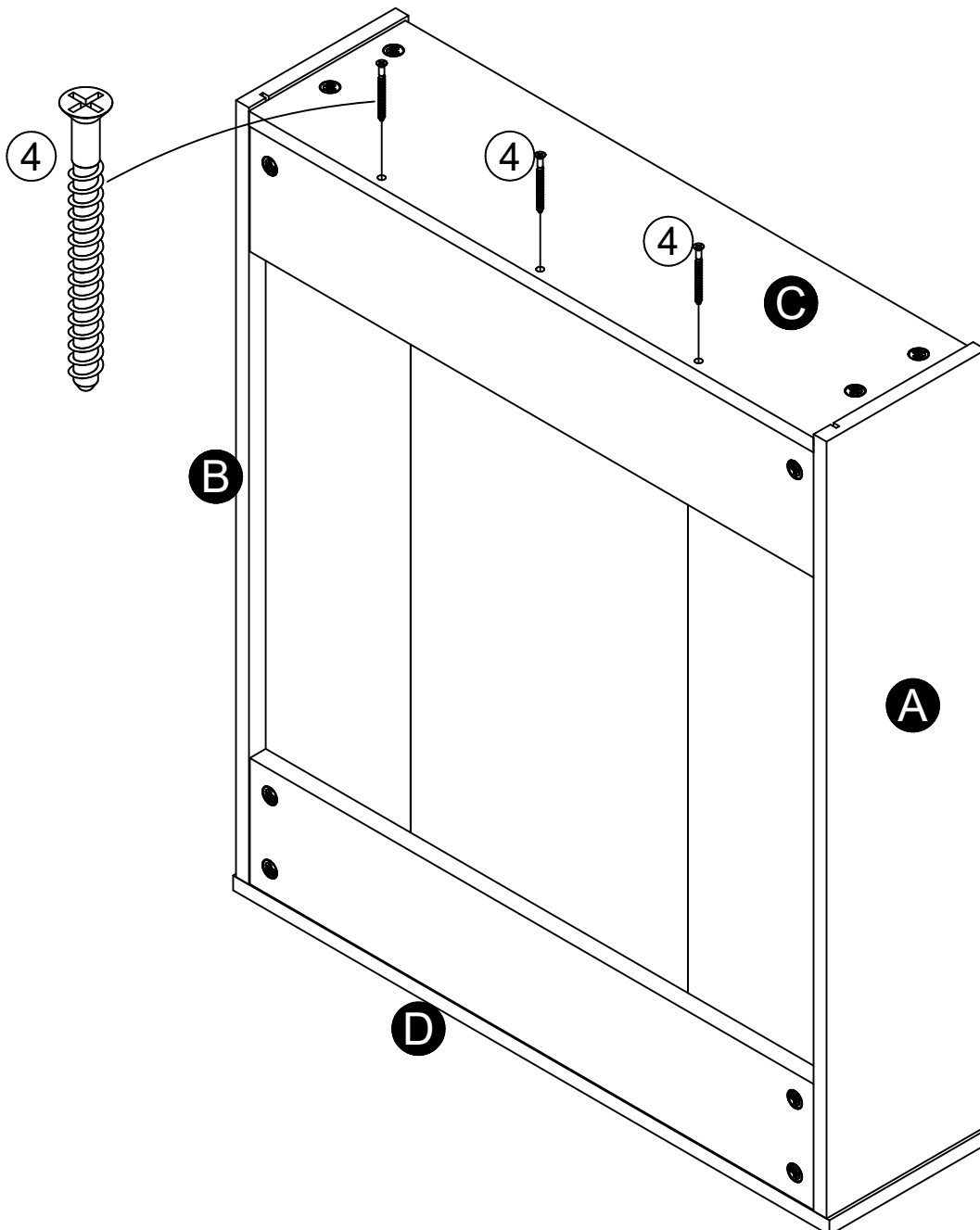

STEP 11

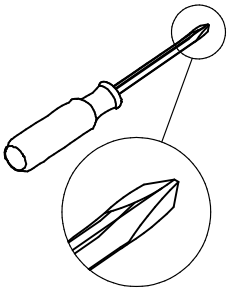

(x12)
#A12120

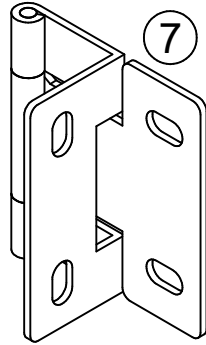

(x4)
#A60015

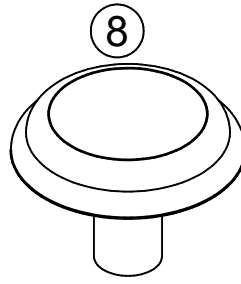

(x2)
#A51960



(x2)
#A17300

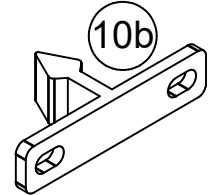

(x2)
#A30030

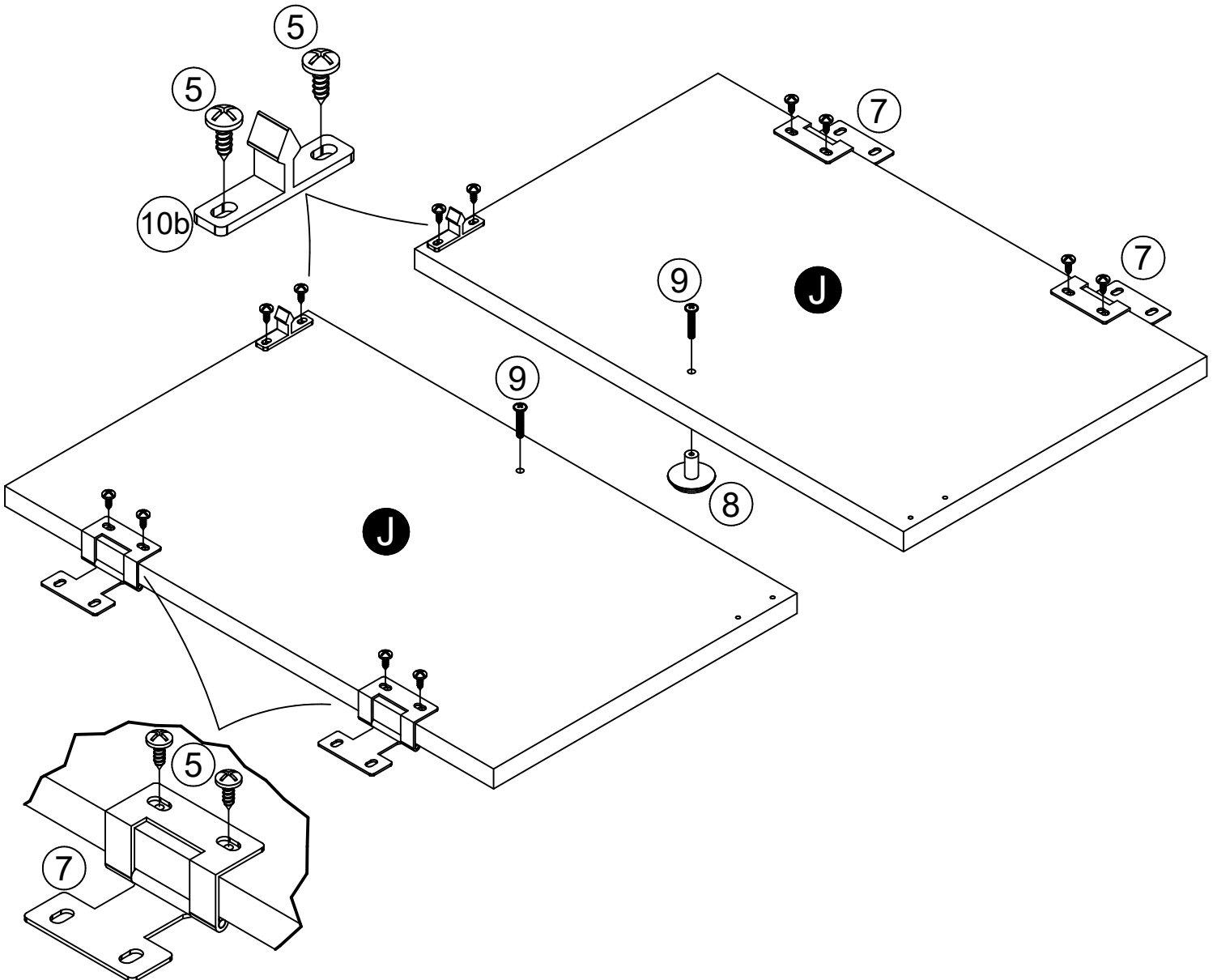

STEP 12

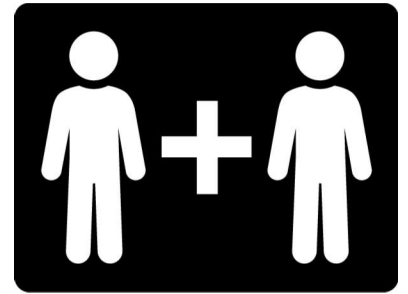
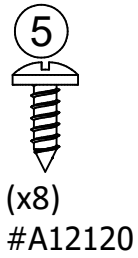
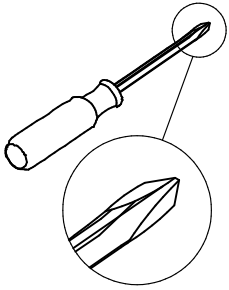

With the help of another person, mount the doors as shown.

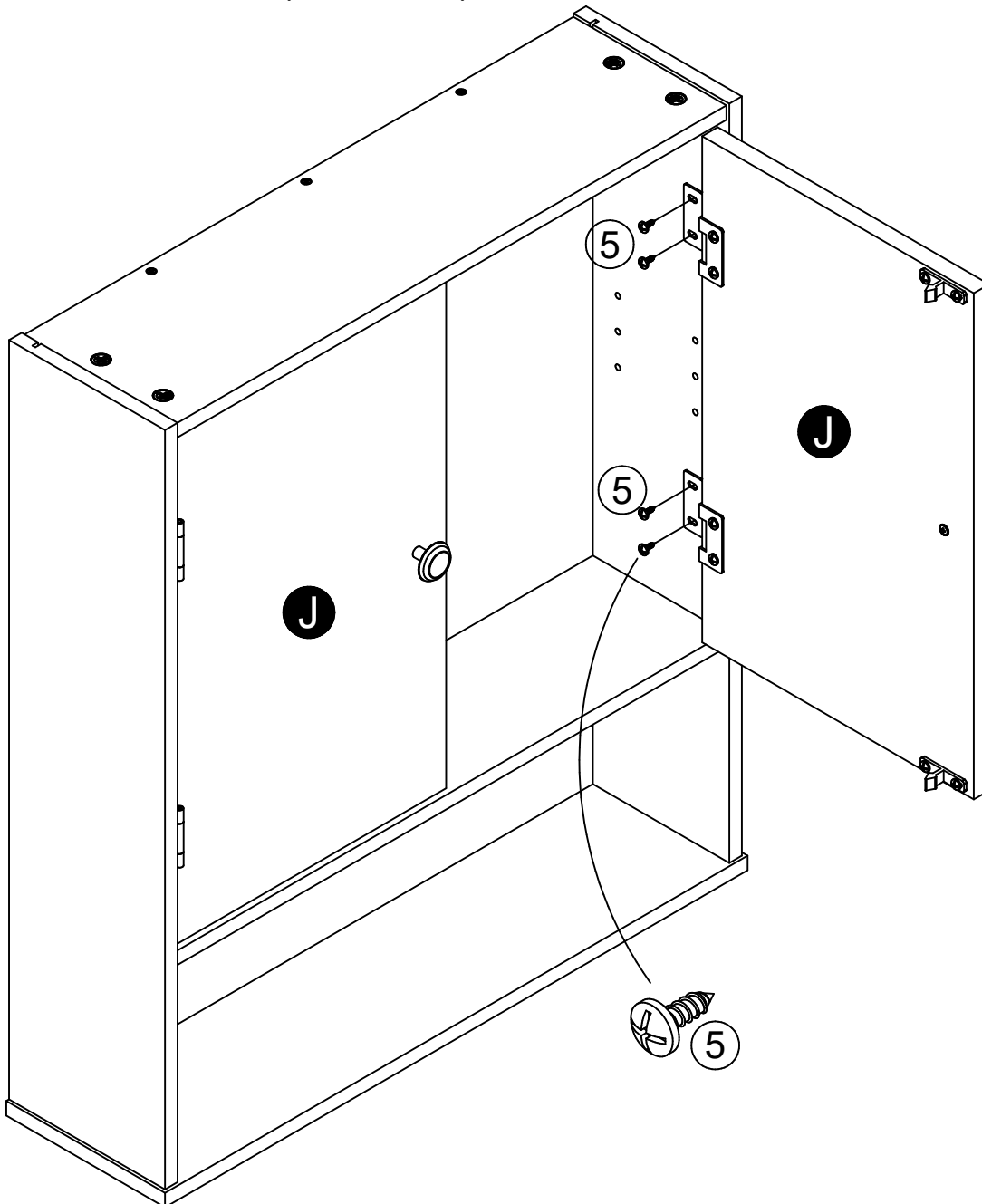

STEP 13

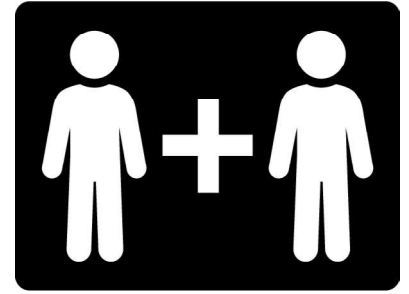
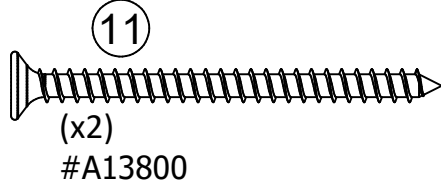
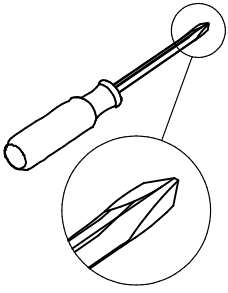

With the assistance of another person, locate and mark the studs in the wall that the cabinet will be mounted to. Mark the location of the studs with a pencil. Position the wall hanger (I) on the wall and mark the locations of the studs on the top rail (G). Drill two 3/16" diameter holes in the wall hanger (I) at the stud locations. Using a level, attach the wall hanger (I) to the wall with two screws (11) as shown. It is important that the wall hanger (I) is mounted to a minimum of at least two studs. With the help of another person, place the assembled component onto the wall hanger (I) so the two beveled edges on the top rail (G) and wall hanger (I) mate together.

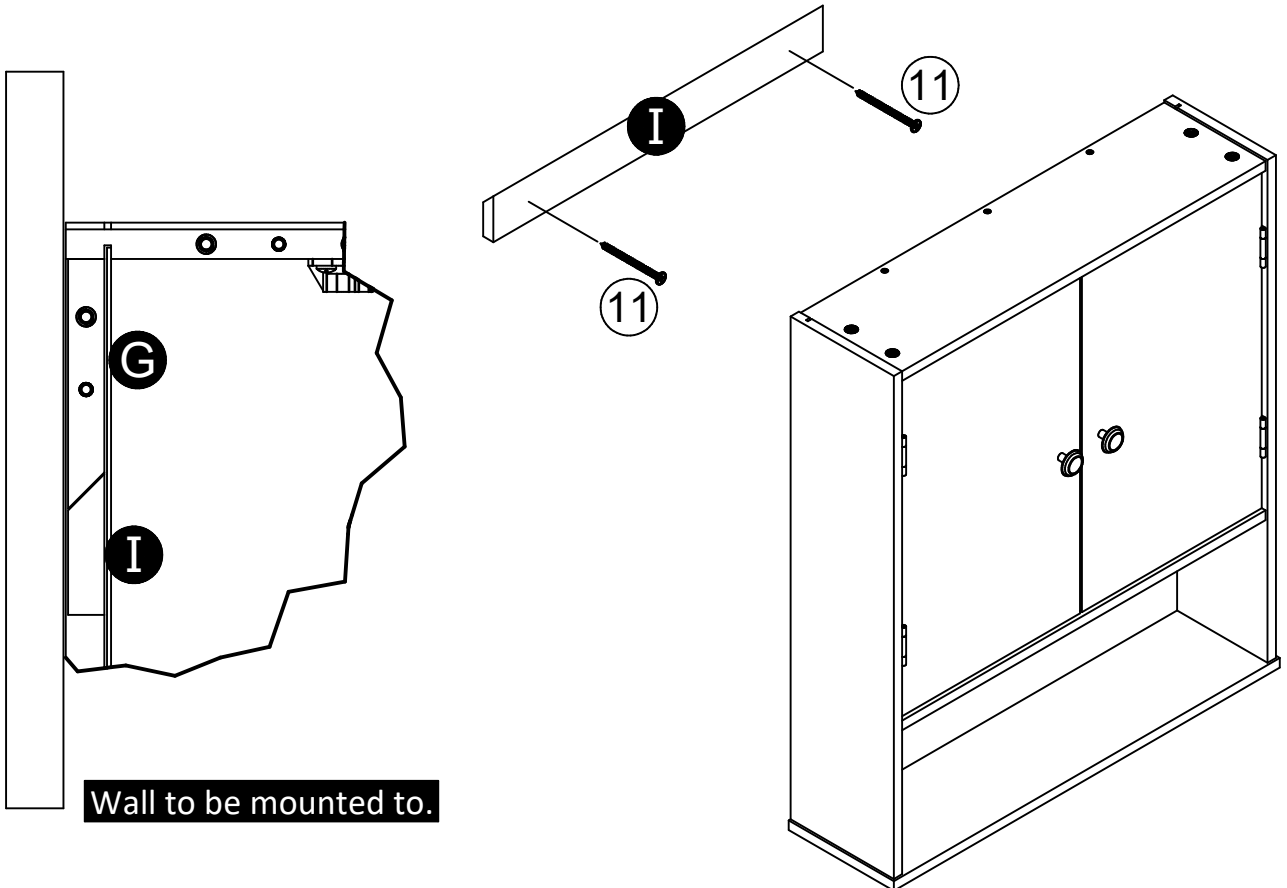

STEP 14

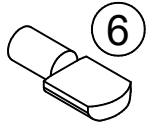

(x4)
#A80250

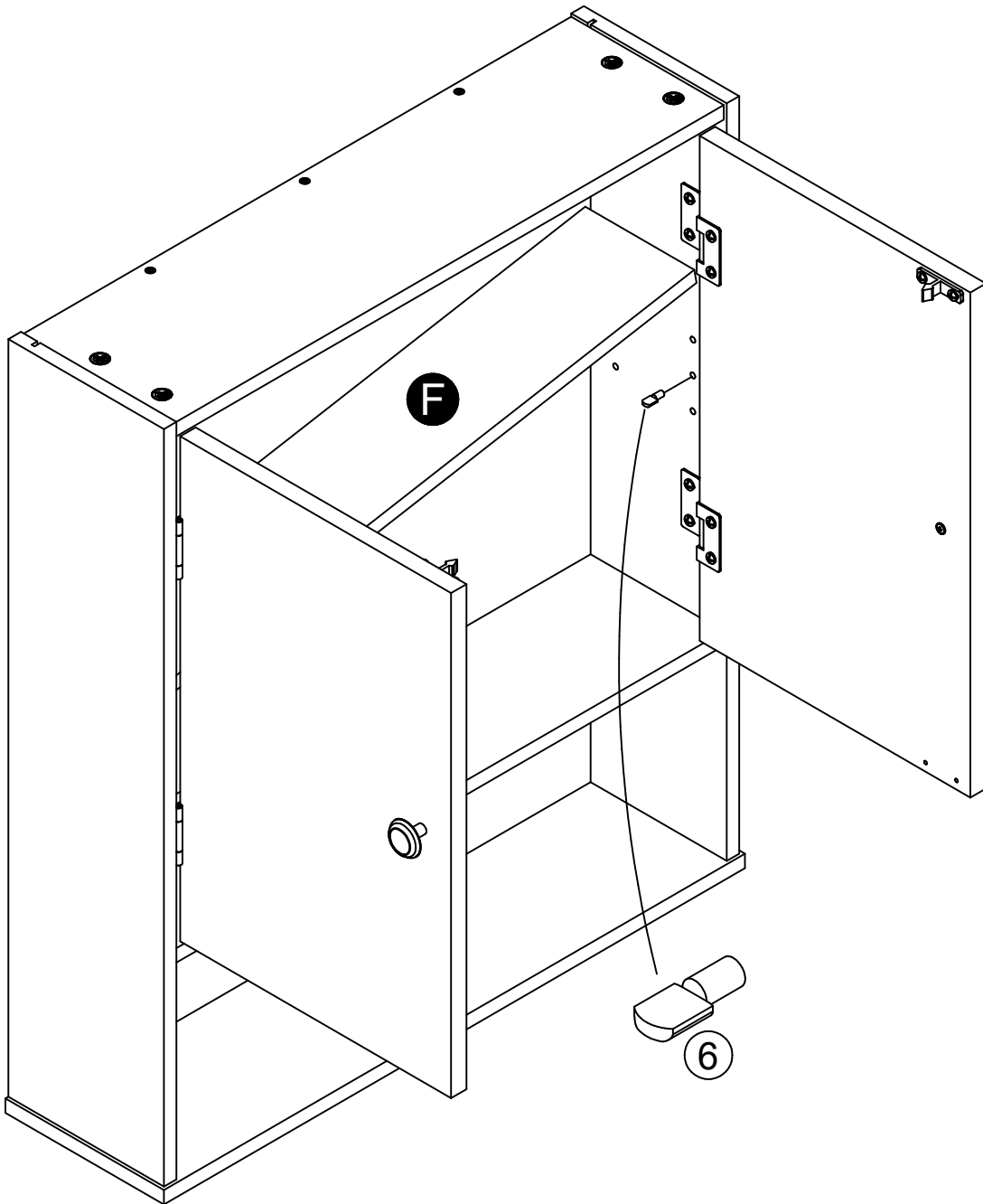

STEP 15

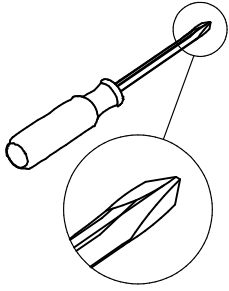

Notice: The holes in the hinges (7) and plastic catches (10a & 10b) are slotted. Adjustments can be made by loosening screws, make needed adjustments and retighten screws.

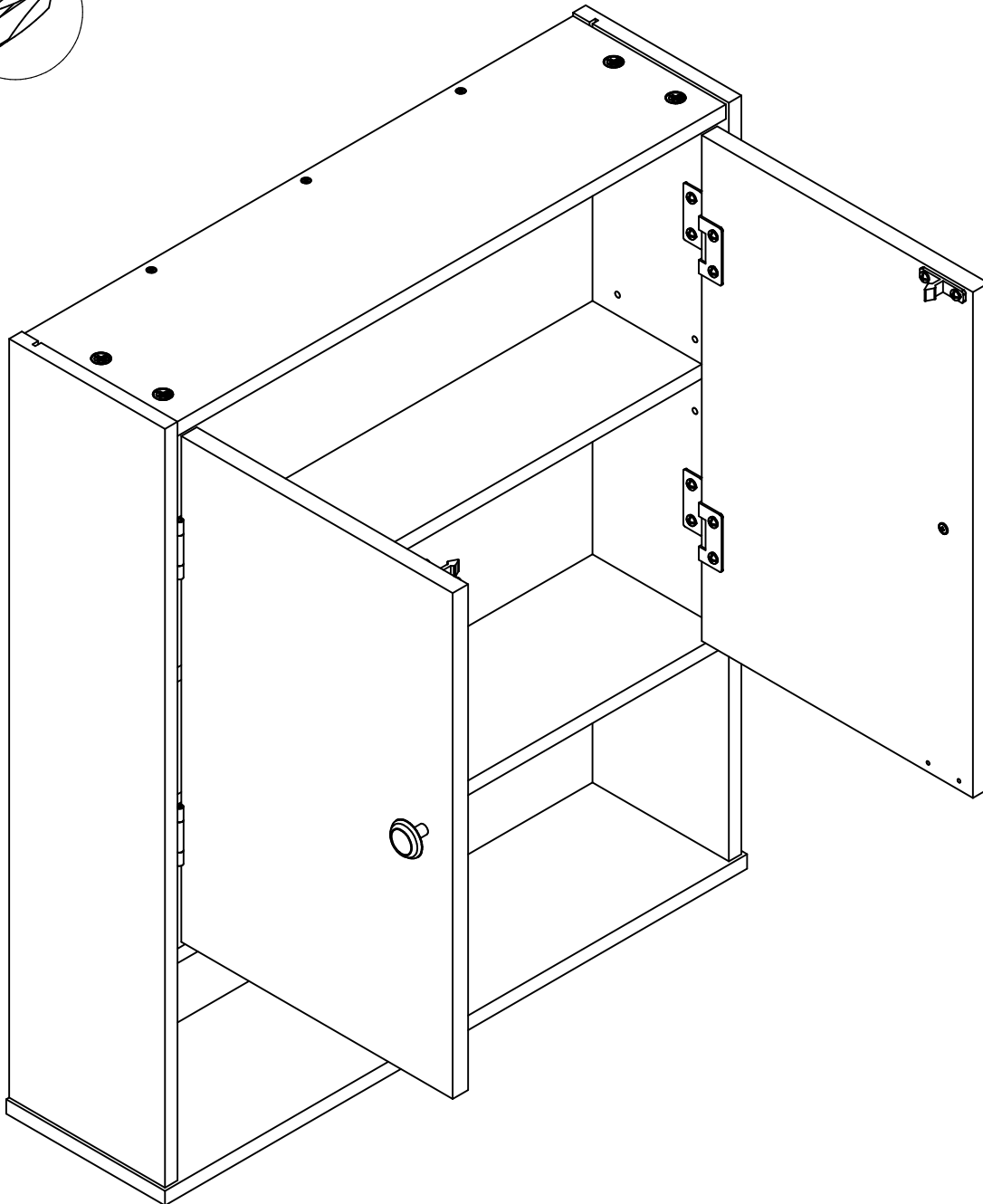

Maximum Loads

This unit has been designed to support the maximum loads shown. Exceeding these load limits could cause sagging, instability, product collapse, and/or serious injury.

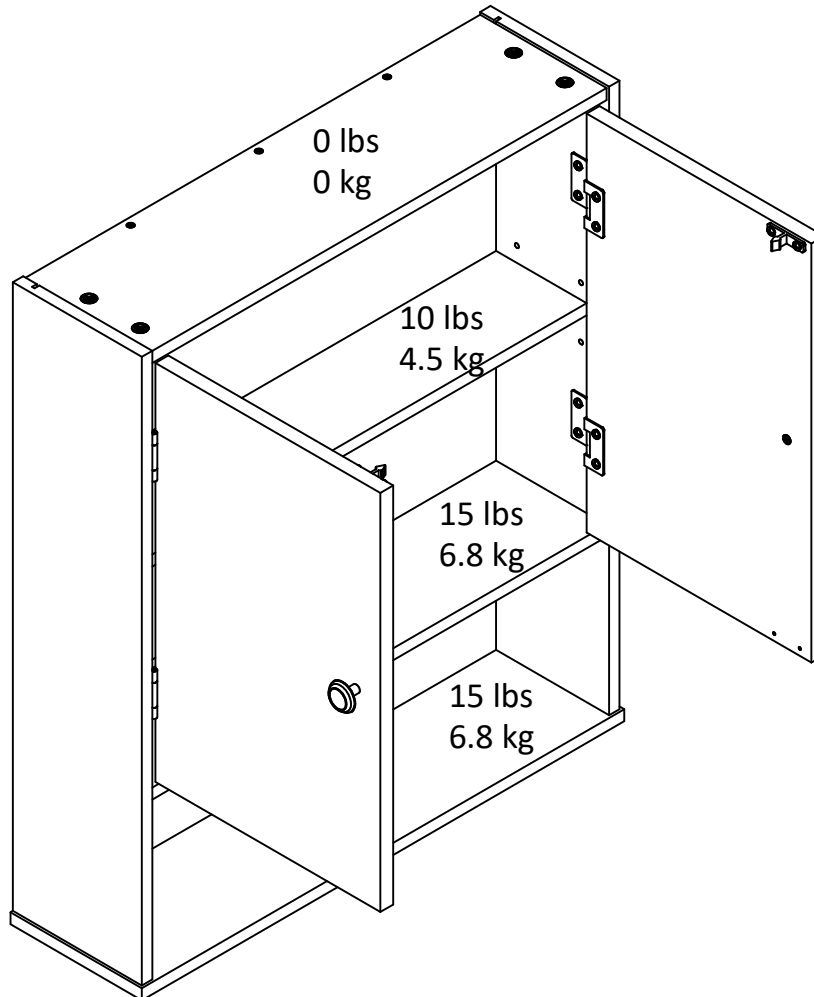

Warning: Risk of injury to persons - do not place a television on this furniture. This furniture is not approved for use with a television.

Certificate of Conformity

1. This certificate applies to the Dorel Home Furnishings, Inc. product identified by this instruction manual.
2. This certificate applies to compliance of this product with the CPSC Ban on Lead-Containing Paint (16 CFR 1303).
3. This product is distributed by: Dorel Home Furnishings, Inc.
410 East First Street South
Wright City, MO 63390
636-745-3351
4. Site of Manufacture: Tiffin OH
5. See front page of instruction manual for date of manufacture.

Register your product to receive the following:



- * New trend details - sneak peek on what's new
- * Surveys - have a voice within our community
- * Exclusive deals and discount codes
- * Quick and easy replacement part service

To register your product, visit systembuild.com

5 Star Rating



Visit your local retailer's website, rate your purchased product and leave us some feedback!

We would like to extend a big "Thank You" to all of our customers for taking the time to assemble this Systembuild product, and to give us your valuable feedback.

*Thank
You!*

Cubierta Delantera

Este libro de instrucciones contiene información **IMPORTANTE** de seguridad. Por favor lea y manténgalo para referencia en el futuro.

No Regrese este producto! Comuníquese con nuestro amistoso equipo de servicio al cliente para obtener ayuda.

Llámenos al: 1-866-452-4081 (Gratis) Lunes - Viernes 9am - 5pm CST

Visitar: www.systembuild.com

PRECAUCION

Este mueble puede volcarse y causar graves heridas y/o muerte.

Anclar el mueble a un poste de madera en la pared (si esto se requiere).

No Permita que los niños monten el mueble.

Mantenga los artículos más pesados en los cajones de abajo.

Consejos Útiles (página 2)

- Abra su artículo en el área donde usted planea utilizarlo para evitar levantar y moverlo menos
- Identificar, ordenar y contar las piezas antes de intentar ensamblar
- Las clavijas de compresión se golpean con un martillo
- Las diapositivas están marcadas con una R (derecha) y L (izquierda) para la colocación correcta
- Asegúrese de que siempre este el punto localizado en la parte superior de bloqueador de leva este volteado hacia borde exterior
- Utilizar todos los clavos para el panel de atrás y distribuirlos por igual
- El panel de atrás debe utilizarse para asegurarse de que la unidad quede fija y firme
- No use químicas fuertes ni limpiadores abrasivos en este artículo
- Nunca empuje, tire ni arrastre los muebles

Antes de Que Empieces (página 3)

- Lea cuidadosamente cada paso y siga el orden correcto

- Separar y contar todas sus piezas y hardware

- Dése suficiente espacio para el proceso de ensamble

- Tenga las siguientes herramientas: destornillador de cabeza plana, #2 cabeza Phillips

Destornillador y martillo

- Precaución: Si usa un taladro electrónico o un destornillador eléctrico para atornillar, por favor asegúrese que deje de atornillar cuando el tornillo este apretado. Fallar hacer esto puede causar barrer el tornillo.

Sistema de fijar el bloqueo de leva (página 3)

Esta sistema de fijar el bloqueo de leva sera usado en todo el proceso ensamble.

Página 15

Despliegue el panel trasero. Deslice dentro de la ranura del panel izquierdo (A), el panel derecho (B) y la parte superior (C).

Página 17

Con cuidado, dele vuelta a su unidad como se muestra aquí. Asegure la parte superior (C) al riel superior (F) como se muestra, con los tornillos (4).

Página 19

Con ayuda de otra persona, realice el montaje de las puertas como se indica aquí.

Página 20

Con ayuda de otra persona, ubique y marque los pernos en la pared en la que se instalará el gabinete. Marque la posición de los pernos con un lápiz. Coloque el soporte de pared (I) en la pared y marque la posición de los pernos en el riel superior (G). Perfore dos agujeros de 3/16" de diámetro en el soporte de pared (I) en las posiciones de los pernos. Con un nivel, fije el soporte de pared (I) a la pared con dos tornillos (11) como se indica aquí. Es importante que el soporte de pared (I) se instale al menos con dos pernos. Con ayuda de otra persona, coloque el componente ensamblado en el soporte de pared (I) de modo que los dos bordes biselados del riel superior (G) y el soporte de pared (I) se acoplen entre sí.

Página 22

Atención: Los agujeros de las bisagras (7) y de las abrazaderas plásticas (10a y 10b) cuentan con ranuras. Es posible realizar ajustes aflojando los tornillos, haga los ajustes necesarios y vuelva a apretar los tornillos.

Página 23

CARGA MAXIMA

Esta unidad ha sido diseñada para soportar la carga máxima anotada. El exceder estos límites puede causar inestabilidad, colapsarse y/o causar serias lesiones.

ADVERTENCIA: Riesgo de lesiones a las personas - no coloque un televisor sobre muebles. Este mueble no está aprobado para su uso con un televisor.

Página 24

Registre su producto para recibir lo siguiente:

- * Detalles de nuevas tendencias - Vistazo a lo nuevo
- * Encuestas - aloc su voz entre su comunidad
- * Códigos de ofertas y descuentos exclusivos
- * Fácil y rápido servicio de partes de remplace

Para registrar su producto, visite systembuild.com

Clasificación de 5 estrellas

Visite el sitio web de su tienda local, califique su comprado y denos sus comentarios!

Nos gustaría enviar un gran "Agradecimiento" a todos nuestros clientes por tomarse el tiempo de ensamblar este producto de Systembuild, y por darnos sus valiosos comentarios.

Gracias

Couverture Avant

CE LIVRET D'INSTRUCTION CONTIENT DES INFORMATIONS **IMPORTANTES** SUR LA SÉCURITÉ. VEUILLEZ LIRE ET GARDER POUR UNE RÉFÉRENCE FUTURE

Ne retournez pas ce produit! Contactez notre équipe de service à la clientèle amicale d'abord pour obtenir de l'aide.

Appelez-nous: 1-866-452-4081 (sans frais) du Lundi au Vendredi de 9h à 17h Heure Centrale

Visitez: www.systembuild.com

ATTENTION

Le meuble peut basculer et causer des blessures graves ou la mort.

Ancrer le meuble à une planche murale dans le mur (si indiqué).

Ne laissez pas les enfants grimper sur le meuble.

Placez les articles lourds sur les étagères ou dans les tiroirs inférieurs.

Astuces Utiles (page 2)

-Ouvrez votre article dans la zone que vous prévoyez de le garder pour moins de levage lourd

-Identifier, trier et compter les pièces avant d'essayer d'assembler

-Les goujons de compression sont taraudés avec un Marteau

-Les glissières sont marquées d'un R (droit) et d'un L (gauche) pour un bon placement

-Assurez-vous toujours de faire face la pointe situé sur le haut de la Serrure de Came vers le bord extérieur

-Utiliser tous les clous fournis pour le panneau arrière et les répartir également

-Le panneau arrière doit être utilisé pour vous assurer que votre appareil est robuste

-N'utilisez pas de produits chimiques agressifs ou de nettoyeurs abrasifs sur cet appareil

-Ne jamais pousser, tirer, ou faire glisser votre meuble

Avant de Commencer (page 3)

-Lisez attentivement chaque étape et suivez le bon ordre

-Séparez et comptez toutes vos pièces et matériaux

-Donnez-vous suffisamment de place pour l'assemblage

-Avoir les outils suivants: tournevis à tête plate, #2 tournevis Phillips, et Marteau

-Attention: Si vous utilisez une perceuse électrique ou un tournevis électrique pour visser, veillez à ralentir et arrêter lorsque la vis est bien serrée. Le non-respect de cette consigne peut endommager la vis.

Système de Fixation de Came (page 3)

Ce Système de Fixation de Came sera utilisé tout au long de l'assemblage

Page 15

Dépliez le panneau arrière. Faites glisser dans la rainure du panneau gauche (A), du panneau droit (B) et du haut (C).

Page 17

Retournez soigneusement votre appareil comme indiqué. Fixez le haut (C) au rail supérieur (F) comme indiqué par les vis (4).

Page 19

Avec l'aide d'une autre personne, montez les portes comme indiqué.

Page 20

Avec l'aide d'une autre personne, localisez et marquez les montants du mur sur lequel le cabinet sera monté. Marquez l'emplacement des montants avec un crayon. Positionnez le support mural (I) sur le mur et marquez l'emplacement des montants sur le rail supérieur (G). Percez deux trous de 3/16" de diamètre dans le support mural (I) à l'emplacement des montants. À l'aide d'un niveau, fixez le support mural (I) au mur avec deux vis (11) comme indiqué. Il est important que l'accroche murale (I) soit montée sur au moins deux montants. Avec l'aide d'une autre personne, placez l'élément assemblé sur le support mural (I) de manière à ce que les deux bords biseautés du rail supérieur (G) et du support mural (I) s'emboîtent.

Page 22

Avis : Les trous des charnières (7) et des loquets en plastique (10a et 10b) sont fendus. Les réglages peuvent être effectués en desserrant les vis, en effectuant les ajustements nécessaires et en resserrant les vis.

Page 23

CHARGES MAXIMALES

Ce meuble a été conçu pour supporter les charges maximales indiquées. En excédant ces limites de charge, le meuble pourrait devenir instable, s'effondrer, et/ou causer des blessures graves.

AVERTISSEMENT : Risque de blessure corporelle - ne pas placer une télévision sur ce meuble. Ce meuble n'est pas approuvé pour une utilisation avec une télévision.

Page 24

Enregistrez votre produit pour recevoir les éléments suivantes:

- * Détails sur les nouvelles tendances - un aperçu sur les nouveautés
- * Sondages - avoir une voix au sein de notre communauté
- * Offres exclusives et codes promo
- * Service de pièces de rechange rapide et facile

Pour enregistrer votre produit, visitez systembuild.com

5 Étoiles

Visitez le site Web de votre détaillant local, évaluez votre produit acheté et laissez-nous quelques commentaires !

Nous tenons à offrir un grand "Merci" à tous nos clients pour avoir pris le temps d'assembler ce produit "Systembuild", et de nous donner vos commentaires précieux.

Merci